

<b>Product Name:</b>	<b>Cell Strainer</b>
<b>Product Application:</b>	<p>NEST cell strainer can be used to obtain uniform single cell suspension which is compatible with 50ml centrifuge tubes of most popular brands on the market.</p> <ul style="list-style-type: none"> <li>• Sample filtration</li> <li>• Sample preparation for Flow Cytometer</li> <li>• Filtration of viscous proteins from inactivated serum</li> <li>• Isolating primary cells to consistently obtain a uniform single cell suspension from tissues</li> <li>• Preparation of single-cell suspensions of blood cells in bone marrow, pancreas, thymus, and lymph nodes</li> <li>• Stem cell preparation</li> <li>• Preparation of samples prior to freezing</li> </ul>
<b>Product Materials:</b>	<b>PP frame + Nylon strainer</b>
<b>product Specifications:</b>	<p>Temperature range: stored at room temperature</p> <p>Shelf life: 5 Years after date of production ( ensure package is in good)</p>
<b>Sterilization:</b>	<p><b>Yes.</b></p> <p>Sterilized by E-beam, Sterility Assurance Level: SAL=10<sup>-6</sup>. The product has been irradiated and dosimetrically released based on ANSI/AAMI/ISO 11137</p>
<b>Pyrogens:</b>	Non-Pyrogenic
<b>RNase/DNase:</b>	DNase/RNase free
<b>BSE/TSE:</b>	These products are deemed animal free.
<b>Performance Testing:</b>	<p>Each manufacturing lot is sampled and tested in accordance with standard operating procedures.</p> <p>Appearance inspection: qualified      Packaging inspection: qualified</p>
<b>Features</b>	<ol style="list-style-type: none"> <li>1. Fits nearly all 50ml conical tubes.</li> <li>2. Tab molded within upper ring enables easy sterile handling.</li> <li>3. Individually Packaged.</li> <li>4. Non-pyrogenic and DNase/RNase free, non-cytotoxicity.</li> </ol>

## Product Range

Cat. No.	Spec(um)	Color	/Pack	/Case
258366	40	Blue	1	50
258365	70	White	1	50
258364	100	Yellow	1	50
258369	40	Blue	1	50
258368	70	White	1	50
258367	100	Yellow	1	50

## Product picture



Technical Drawing

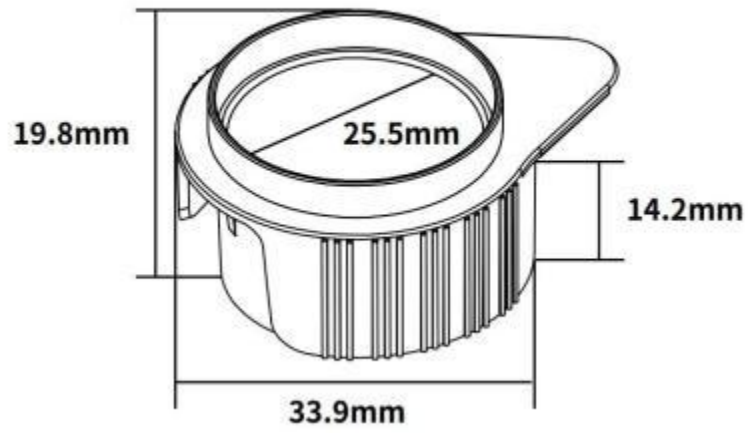

258366 / 258365 / 258364

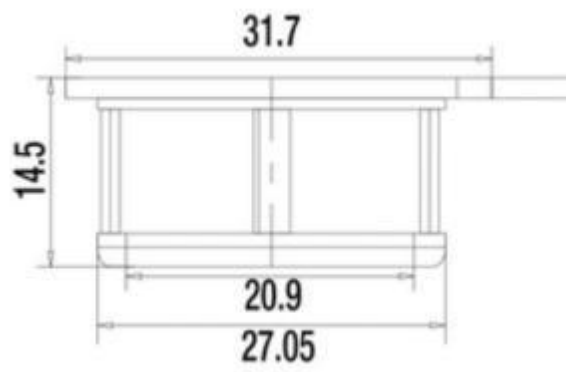

258369 / 258368 / 258367